

# The Corporation of the Township of Brock

## By-law Number 3309-2024

Being a By-law to regulate and require owners of privately owned outdoor swimming pools or hot tubs to erect and maintain fences and gates around such pools.

---

**Whereas** the Council of the Township of Brock deems it advisable to enact a new by-law and repeal By-law 3216-2023 as amended.

**Whereas** section 11(3) of the Municipal Act S.O. 2001, c.25, as amended (the "Act"), authorizes a lower-tier municipality to pass by-laws with respect to fences.

**And whereas** section 444 of the Act authorizes a municipality where it is satisfied that a contravention of a by-law has occurred, the municipality may make an order requiring the person who contravened the by-law or who caused or permitted the contravention or the owner or occupier of the land on which the contravention occurred to discontinue the contravening activity.

**And whereas** section 445 of the Act authorizes a municipality where it is satisfied that a contravention of a by-law of the municipality passed under the Act has occurred, the municipality may make an order requiring the person who contravened the by-law or who caused or permitted the contravention or the owner or occupier of the land on which the contravention occurred to do work to correct the contravention.

**And whereas** section 446 of the Act authorizes a municipality to direct a matter or thing to be done under a by-law to be done at the person's expense, and should the person fail to do such matter or thing as directed by the by-law, to recover the costs of doing the thing or matter by action or by adding the costs to the tax roll and collecting them in the same manner as taxes.

**Now therefore** the Council of the Corporation of the Township of Brock enacts as follows:

### 1. Short title

This By-law may be cited as the Pool Enclosure By-law.

### 2. Definitions

- 1) In this By-law;
  - (a) **"Abandoned Pool"** means a Swimming Pool or Hot Tub that is abandoned whether or not it contains water and whether or not it is being used, or a Swimming Pool by reason of its state of repair is incapable of safely being used and may include, but is not limited to, its structure, support structure, and containment liner, deck or state of its being maintained.
  - (b) **"Applicant"** means the owner of a property who applies for a permit, or the person authorized in writing by the owner to apply for a permit on the owner's behalf.
  - (c) **"Enclosure"** means a fence, wall or other structure, including doors and gates, surrounding a Swimming Pool or Hot Tub to restrict access thereto.
  - (d) **"Chief Building Official"** means the Chief Building Official appointed by The Township of Brock.
  - (e) **"Fence"** means any structure constructed of posts, boards, palings, rails, wire, masonry or similar materials or any combination thereof to enclose any outdoor area or define a property boundary.

- (f) **“Height”** means the distance measured from the grade to the highest point of the fence exclusive of the posts.
- (g) **“Hot tub”** means any artificially enclosed body of water consisting of water heating units and/or air jets for bathing or other purposes as intended and shall include a whirlpool or spa or other similar device.
- (h) **“Inspector”** means a Building Inspector for the Township of Brock.
- (i) **“Officer”** means a Municipal Law Enforcement Officer, or a Building Inspector employed by the Township of Brock.
- (j) **“Owner”** means the person in possession of the property on which the swimming pool is located.
- (k) **“Person”** means an individual, sole proprietorship, partnership, limited partnership, trust or body corporate, or an individual in his or her capacity as a trustee, executor, administrator, or other legal representative.
- (l) **“Swimming Pool”** means a water filled enclosure, permanently constructed or portable, whether above or in ground capable of holding water to a depth of more than twelve (12) inches, maintained or used, or which may be used for swimming or bathing; including reflecting pools and other such structures used as a part of the landscaping of a property but excluding existing natural bodies of water or streams
- (m) **“Township”** means the Corporation of the Township of Brock.

### 3. Permit applications

#### 1)

- (a) To obtain a pool enclosure permit, the applicant shall file an application through the Cloudpermit portal by accessing the Township’s website <https://www.townshipofbrock.ca/en/building-and-business-development/building-permits> or in writing by completing an application form available from the Building Department for the Township.
- (b) Every permit application shall state the name, address, telephone number, e-mail address of the owner, applicant or person hired to conduct the construction as the case may be.
- (c) Every permit application shall be accompanied by a site plan that clearly indicates:
  - i. Lot size and dimensions of the property,
  - ii. Setbacks from property boundaries for existing and proposed pools, hot tubs, pool decking, buildings, septic systems, wells and water courses, including distance separation from each of these features,
  - iii. Fences and gates along with the proposed construction materials to be clearly labelled including height of fences and gates along with self-closing devices indicated,
  - iv. existing rights of way, easements, and municipal services to be noted.

A sample site plan can be found in Schedule ‘A’ of this by-law.

- (d) Incomplete permit applications will only be held for a maximum of 60 days and where no progress or updates have been provided on the file, the application will be cancelled. Where work has commenced on the application and fees have been paid, refunds will be governed by section 4 in this by-law.

#### **4. Fees and refunds**

- 1) The Chief Building Official or designate shall determine the required fees in accordance with the Township's Fees By-law or as otherwise noted in this by-law. The applicant shall pay the fees so calculated. Fees are due at the time of submission or when fees have been calculated. The applicant will be notified of any required fees due. No permit application will be considered complete or be reviewed until such time as the fees calculated are paid in full.
- 2) In the case of withdrawal, or abandonment of an incomplete application, or refusal by the Township for issuance of a permit, upon written request by the applicant, the Chief Building Official shall determine the amount of fees, if any, that may be refunded, in accordance with subsection 3) below.
- 3) In determining a refund of the fee where one is requested in writing,
  - (a) Where an application is filed, administration function has been performed – 75% shall be refunded.
  - (b) Where an application is filed, administration function has been performed and the plans review process has begun – 40% shall be refunded.
  - (c) Where a permit has been issued and no field inspections have occurred – 30% shall be refunded.
  - (d) Where a permit has been issued and a minimum of one field inspection has occurred – 0% shall be refunded.
  - (e) The administrative fee is nonrefundable.
  - (f) Notwithstanding the above, no refund shall be made for an amount less than \$150.00. Interpretation of this section will be at the sole discretion of the Chief Building Official.
- 4) An administrative fee is applicable to all permit applications and shall be set out in the Township's Fees By-law, as amended.
- 5) Where construction has started on a pool or hot tub or where a pool or hot tub has been installed without the benefit of a permit, the application fees shall be doubled.
- 6) Where an Officer, Inspector or the Chief Building Official discover that construction has started or a pool or hot tub has been installed without the benefit of permit, a compliance inspection fee shall be applicable for each compliance inspection until a permit has been issued for the works and shall be set out in the Township's Fees By-law.
- 7) Where an Officer, Inspector or the Chief Building Official has found noncompliance of this by-law and have issued an Order to Discontinue or an Order to Comply pursuant to Section 444(1) or 445(1) of the Municipal Act, the fee to administer the Order shall be set out in the Township's Fees By-law as amended.
- 8) Where an Order issued under this by-law is registered or discharged on title of a property, the fee shall be set out in the Township's Fees By-law
- 9) Where an additional inspection is required after a final inspection has failed two (2) times, the additional inspection fee shall be in accordance with the Township's Fees By-law.
- 10) Fees are subject to an increase annually as determined by the Township's Fees By-law.

## 5. General provisions

- 1) No person shall erect a fence, gate, excavate for or erect a privately owned swimming pool or hot tub until plans for such fences, gates and swimming pool have been submitted, and a permit certifying approval has been issued by the Chief Building Official, upon payment of the prescribed fees.
- 2) No person shall place water in a privately owned swimming pool or hot tub or allow water to remain therein unless the enclosure prescribed by this By- law has been erected.
- 3) Previously constructed and approved pool enclosures shall be considered legal. Pool enclosures which have not received prior approval shall comply with the regulations and conditions prescribed in this By-Law.
- 4) Replacement or construction of all swimming pool enclosures shall conform to the provisions of this By-Law and require permits under this bylaw unless otherwise noted.
- 5) Subject to the provisions of the Township's Zoning By-law, no person shall construct, erect, maintain or permit to be constructed, erected, or maintained, on any property a fence which, in the opinion of the Officer, by reason of its location, design or materials, obstructs the vision of drivers, either when leaving a roadway or when entering a roadway from another roadway or driveway, or which obstructs or detracts from the visibility or effectiveness or any traffic sign or control device on a public street or which, for any other reason, constitutes a hazard.
- 6) There shall be a minimum 1.2 metre (4 feet) separation between the fence and the exterior edge of a swimming pool.
- 7) A hot tub, which is enclosed by a substantial, structurally adequate hard cover permanently attached to it, or to its supporting structure and the cover is securely fastened and locked to always prevent access when not in use, shall be exempt from the fence and gate provision of this by-law but shall require a permit. Every owner of a hot tub shall keep the hot tub covered and always locked when a responsible person is not present and supervising its use.
- 8) Where an application is made for a swimming pool in a subdivision that has not been assumed by the Township, the application shall be accompanied by a letter authorizing the construction of a swimming pool from the developer of the subdivision.
- 9) The provisions of this By-law requiring the erection of a fence shall not apply to an above ground pool that complies with the following standards:
  - (a) The exterior sides of the pool are not less than 1.2 metres (4 feet) above grade,
  - (b) A guard not less than 91.4 centimetres (36 inches) high is provided around any platform or deck unless otherwise required by the Ontario Building Code. Building permits may be required for the applicable guards.
  - (c) The outside walls of any swimming pool structure and any guard is free of any element or attachment that may facilitate climbing.
  - (d) No part of the swimming pool or adjoining deck structure are located closer than 1.2 metres (4 feet) to any lot line, and to

the point where a user of the above ground pool gains access to the pool is protected by a gate and enclosure which complies with the fence and gate provisions of this By-Law.

## 6. Provisions for fences and gates

- 1) The fence to enclose a swimming pool or hot tub shall be constructed in a good workmanlike manner and shall meet the following requirements:
  - (a) Every fence shall not be less than 1.2 metres (4 feet) in height nor greater than 1.8 metres (6 feet) in height subject to general provisions as set out in this By-law.
  - (b) Every fence shall be constructed of vertically boarded wood, solid wood, chain link, masonry, plastic, metal or other materials and construction providing an equivalent degree of safety and acceptable to the Inspector.
  - (c) Every fence shall be so constructed so that no rails or other horizontal or diagonal bracing or attachments that may facilitate climbing, shall be located on the outside of the fence.
  - (d) Every fence shall be constructed in such a manner that:
    - i. Vertical boards shall not be less than 1.9 centimetres (.75 inches) by 8.9 centimetres (3.5 inches) lumber and shall be spaced not more than 3.8 centimetres (1.5 inches) apart where horizontal rails are spaced less than 1.2 metres (4 feet) apart and not more than 10.16 centimetres (4 inches) apart where horizontal rails are spaced at least 1.2 metres (4 feet) apart.
    - ii. Where vertical boards of 1.9 centimetres (.75 inches) by 8.9 centimetres (3.5 inches) have been used and the horizontal spacing exceeds 3.8 centimetres (3.5 inches), a vertical board of not less than 1.9 centimetres (.75 inches) by 3.8 centimetres (1.5 inches) may be used as a spacer to reduce the horizontal opening to less than the minimum required 3.8 centimetres (3.5 inches).
    - iii. Vertical boards shall be attached to horizontal rails that are not less than 3.8 centimetres (1.5 inches) by 8.9 centimetres (3.5 inches) lumber and that are supported on substantial posts with a minimum dimension of 8.9 centimetres (3.5 inches) spaced not more than 2.4 metres (8 feet) apart and embedded to a minimum depth of 90 centimetres (35.4 inches) below grade.
    - iv. The maximum space between the grade level and the bottom of the fence shall not exceed 10.16 centimetres (4 inches) at any point.
  - (e) A metal picket fence used to enclose a swimming pool shall be constructed in such a manner that;
    - i. Vertical pickets shall be spaced not more than 3.8 centimetres (1.5 inches) apart where horizontal rails are spaced less than 1.2 metres (4 feet) and not more than 10.16 centimetres (4 inches) apart where horizontal rails are spaced at least 1.2 metres (4 feet) apart.
    - ii. Horizontal rails shall be supported on substantial posts not more than 2.4 metres (8 feet) apart and embedded in concrete to a minimum depth of 90 centimetres (35.4 inches) below grade.
  - (f) Every chain link fence shall be constructed in such a manner that;

- i. There shall be no opening that exceeds a horizontal dimension greater than 5.1 centimetres (2 inches).
  - ii. The mesh gauge shall consist of 12-gauge galvanized steel wire or 14 gauge steel wire covered with vinyl coating or such other equivalent material.
  - iii. The gate and terminal posts shall be minimum 4.8 centimetres (1.9 inches) diameter and embedded in the ground to a depth of 76 centimetres (30 inches) in 20 centimetres (8 inches) diameter concrete.
  - iv. Intermediate posts shall be minimum 3.8 centimetres (1.5 inches) diameter and embedded 76 centimetres (30 inches) in the ground.
  - v. The top rail shall be a minimum 3.2 centimetres (1.25 inches) and the bottom wire shall be minimum 9 gauge galvanized, threaded through the mesh and looped and fastened to each post.
  - vi. The gate frame shall be minimum 3.2 centimetres (1.25 inches) and the posts shall be spaced a maximum distance of 2.4 metres (8 feet).
- (g) Every fence shall be constructed or erected to have the only means of entry through the fence be by approved gates or doors which provide a degree of safety acceptable to the Inspector.
- (h) No person shall construct, erect, maintain or cause to be constructed, erected or maintained, any swimming pool fence which contains barbed wire.
- (i) No person shall construct, erect, maintain or cause to be constructed, erected or maintained, any swimming pool fence which contains any device for projecting an electrical current through the swimming pool fence.
- (j) A swimming pool enclosure shall be designed and constructed so that the principal entrance to any main building shall be located outside the enclosed area.
- (k) Where a wall of a building forms part of a swimming pool enclosure, any entrance through the wall to the enclosed area shall be no closer than 1.2 metres (4 feet) horizontally to the water's edge of the pool and shall be protected by a door that is;
  - i. Kept locked at all times except when the enclosed area is in use.
  - ii. Self-closing, self-latching and equipped with a lockable device installed at least 1.53 metres (5 feet) above floor level if the door leads from any other area than a living area of a building.
- (l) A swimming pool gate shall meet the following requirements:
  - i. Every gate shall be a minimum height of 1.2 metres (4 feet) and meet the requirements noted within this by-law.
  - ii. Every gate shall be supported on substantial hinges and shall be equipped with self-closing and self-latching devices placed at the top and on the inside of the gate providing a degree of safety acceptable to the Inspector.
  - iii. Every gate shall be of the same construction equivalent to that required of the fence.
  - iv. Every gate shall extend down with no gap more than 100 millimetres (3.94 inches) of the ground or floor level.

## **7. Abandoned pools**

- 1) Where a pool is determined by an Inspector, Officer or Chief Building Official to be an abandoned pool, the Inspector may cause the Owner of the abandoned pool to make what ever repairs or other requirements for compliance with this bylaw or to remove the Swimming Pool from the property.

## **8. Portable swimming pools**

- 1) Where a Pool Permit has been obtained for the installation of a Portable Swimming Pool and all other provisions of this By-Law have been met and the Swimming Pool is removed for storage, a second Pool Permit shall not be required to reinstall the same Portable Swimming Pool provided that the provisions set forth in the original Pool Permit and site plan have not been changed or altered, including size of Swimming Pool, location of Swimming Pool or any other detail that deviates from the original Pool Permit information.

## **9. Administration and Enforcement**

- 1) This By-law shall be administered by the Building Department of the Township.
- 2) This By-law shall be enforced by an Officer as defined within this By-law.

## **10. Orders**

- 1) Where an Inspector is satisfied that a contravention of this By-law has occurred, the Inspector shall notify the owner and/or the permit holder of the particulars with an "Order to Discontinue" pursuant to Section 444(1) or an "Order to Comply" pursuant to Section 445(1) of the Municipal Act and provide a copy of the order and it shall contain:
  - (a) the municipal address and legal description of the land;
  - (b) reasonable particulars of the contravention;
  - (c) the period within which there must be compliance.
- 2) A notice or order issued pursuant to Section 10 of this By-law shall be served personally or posted in a conspicuous place on the property and shall be deemed sufficient immediate service on the owner and/or applicant or an order sent by registered mail shall be deemed to be served no later than the fifth day following the date of mailing.

## **11. Offences**

- 1) No person shall;
  - a) Erect a swimming pool or hot tub without obtaining a permit,
  - b) Place water in an outdoor pool or hot tub without an approved enclosure,
  - c) Fail to maintain a safe enclosure,
  - d) Fail to erect a safe enclosure,
  - e) Fail to comply with an Order issued under this Bylaw,
  - f) Hinder, obstruct, or attempt to hinder or obstruct an Officer, Inspector or Chief Building Official,
  - g) Fail to identify to an Officer, Inspector or Chief Building Official.

**12. Penalties**

- 1) Every person who contravenes any provision of this By-law is guilty of an offence and upon conviction is liable to a fine as provided for in the Provincial Offences Act.
- 2) Every person who is guilty of an offence under this By-law may, if permitted under the Provincial Offences Act, R.S.O. c 1990, c. P33 as amended, pay a set fine, and the Chief Judge of the Ontario Court of Justice shall be requested to establish set fines as set out in Schedule 'B'.
- 3) Schedule 'B' shall not come into force and effect until approved and filed by the Regional Senior Justice, pursuant to Provincial Offences Act Part 1. A copy of this approval shall be attached and form part of this By-law.

**13. Schedules**

Schedules 'A' and 'B' are incorporated into and form part of this By-law.

**14. Severability**

Should any section, subsection, clause, or provision of this By-law be declared by a court of competent jurisdiction to be invalid, the same shall not affect the validity of this By-law as a whole or any part thereof, other than the part so declared to be invalid.

- 15. **That** By-law 1936-2005-PP as amended shall be deemed to be repealed upon the coming into force of this By-law. Upon coming into force, this By-law shall supersede any corresponding By-laws of the Township of Brock which, through inadvertence, may not have been repealed;
- 16. **That** this By-law shall come into force and take effect on and from the date of passage hereof;
- 17. **That**, notwithstanding anything contrary to the rules of procedure, this By-law, be introduced and read a first and second time and be considered read a third time and finally passed this 16<sup>th</sup> Day of December, 2024..

Original signed

---

Mayor  
Walter Schummer

Original signed

---

Clerk/Deputy CAO  
Fernando Lamanna



# SAMPLE SITE PLAN FOR A POOL PERMIT

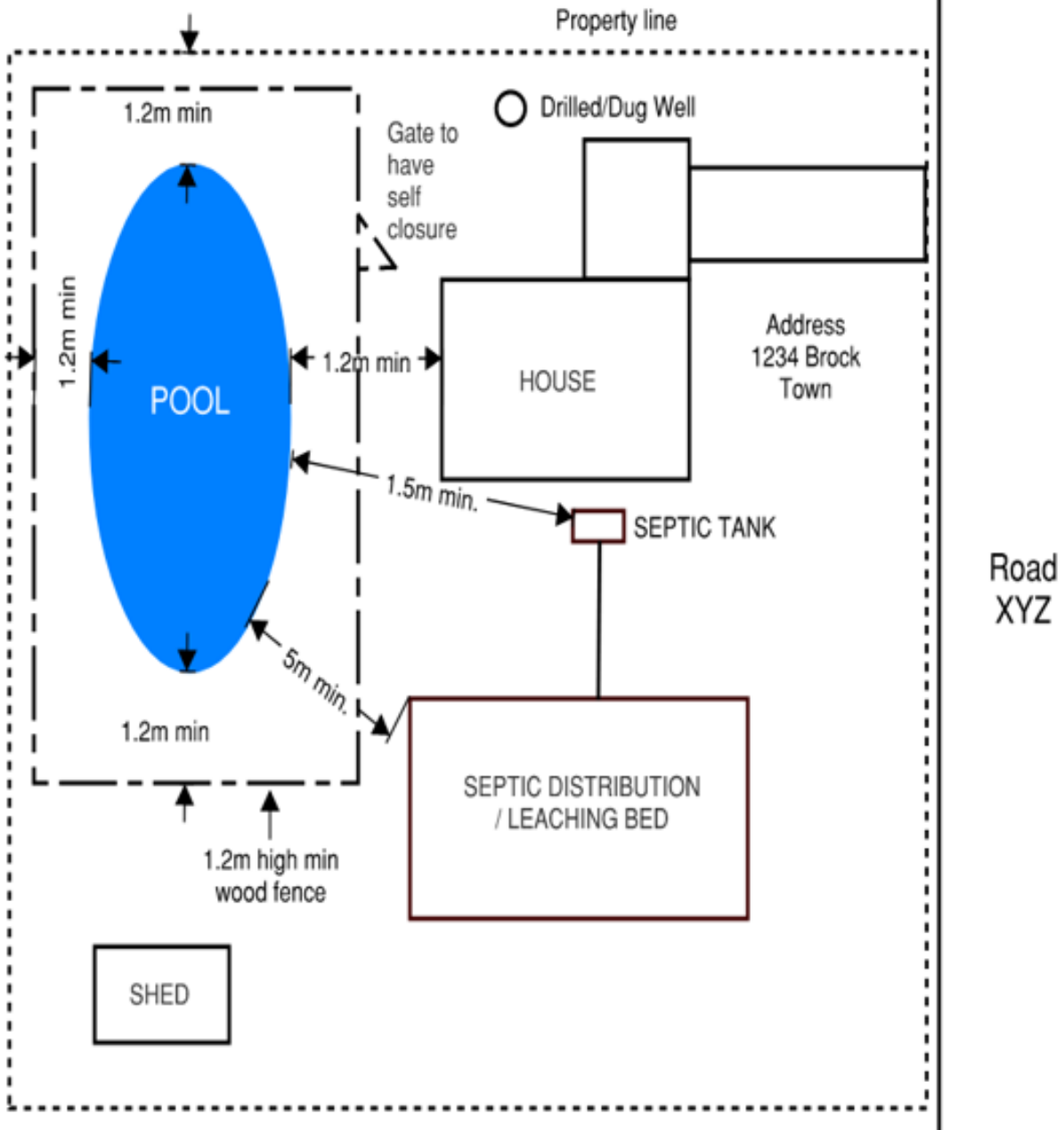

**Schedule B to By-law Number 3309-2024**

Part 1 Provincial Offences Act

Township of Brock

By-law Number 3309-2024 – Pool By-law

Item	Column 1 Short Form Wording	Column 2 Provision Creating or Defining Offence	Column 3 Set Fine
1.	Erect a swimming pool or hot tub without obtaining a permit	11.1) a)	\$500.00
2.	Place water in an outdoor pool or hot tub without an approved enclosure	11.1) b)	\$500.00
3.	Fail to maintain a safe enclosure	11.1) c)	\$500.00
4.	Fail to erect a safe enclosure	11.1) d)	\$500.00
5.	Fail to comply with an Order issued under this Bylaw	11.1) e)	\$500.00
6.	Hinder, obstruct, or attempt to hinder or obstruct an Officer, Inspector, or Chief Building Official	11.1) f)	\$500.00
7.	Fail to identify to an Officer, Inspector, or Chief Building Official	11.1) g)	\$500.00

NOTE: The penalty provisions for offences listed above are Section 12. of By-law 3309-2024, as amended, certified copy of which has been filed.